

2215B 15" LF driver



- **Designed for very high output live sound applications with superior mid-bass performance**
- **ideal for high performance two-way pro audio systems**
- **optimized for compact vented and horn loaded systems**
- **1600 W continuous program power**
- **edge-wound ribbon wire voice coil**
- **proprietary Venturi-vented air gap cooling system**
- **composite Kevlar reinforced cone**
- **proprietary US aerospace industry adhesives and premium materials provide long-term reliable operation without creep and aging effects**
- **very light, stiff and stable moving system ensures driver linearity under extreme stress resulting in uncompressed and clean reproduction of highly transient signals**
- **T- shaped pole piece with dual demodulation rings further minimizes distortion and improves transient response and signal resolution**

SPECIFICATIONS

Nominal diameter	15"/380 mm
Rated impedance	8 Ω
Power handling ¹	800 W
Continuous program power ²	1600 W
Sensitivity ³	100 dB
Rated frequency range ⁴	40 Hz – 2 kHz
Recommended max. XO frequency	1200 Hz
Minimum impedance	6.8 Ω
Cone material	Paper/Kevlar composite
Voice coil diameter	101.6 mm (4")
Voice coil winding	edge wound ribbon wire
Voice coil wire	Copper clad Aluminum
Voice coil former	Fiberglass
Voice coil displacement limit	19 mm
Voice coil winding height	17 mm
Magnetic gap height	10 mm
Suspension	Triple roll, Poly-cotton
Magnet	Ferrite ring
Frame	Cast Aluminum
Recommended enclosure volume	60 – 100 L (2.1-3.6 ft ³)

Thiele-Small parameters

Fs	40 Hz
Sd	881 cm ²
Re	5.6 Ω
Qms	3.8
Qes	0.32
Qts	0.3
Vas	200 dm ³ (L)
Cms	0.18 mm/N
Mms	88 g
BL	19.7 N/A
Le	1.26 mH
Xmax ⁶	6.0 mm

Mounting and mechanical parameters

Overall diameter	387 mm (15.25 in)
Bolt circle diameter	370 mm (14.56 in)
Baffle cut-out diameter	356 mm (14.00 in)
Overall depth	143 mm (5.625 in)
Net weight	9.9 kg (21.8 lbs.)
Shipping weight	12.5 kg (27.5 lbs.)

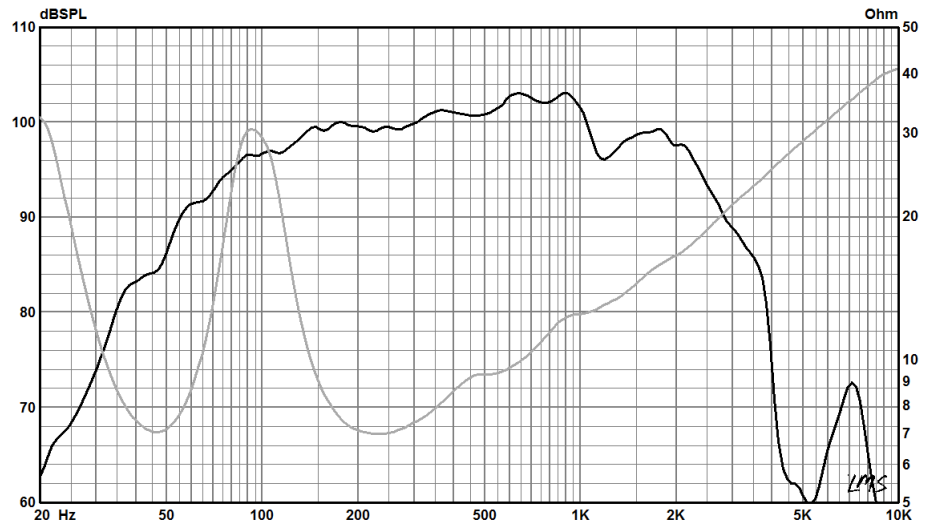
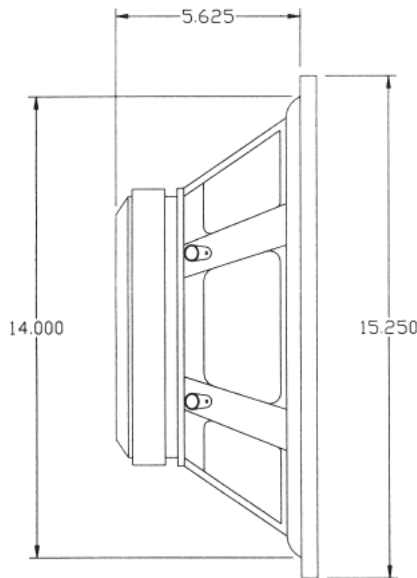

Frequency response and impedance curves of 2215 driver in $V_b=145$ L/F $_b=48$ Hz vented box

Specifications notes

1. As per AES2-1984 Rev.2003. Radian Audio tests power using voltage levels calculated based on rated impedance, according to AES and IEC 60268-5 standards, as better reflecting real life operating conditions. To be distinguished from power specification approach that uses minimum impedance, resulting in inflated power rating.
2. Continuous program power is defined at 3dB higher than AES power and reflects power handling capacity for typical live music and cinema content reproduction.
3. Driver mounted in specified enclosure, measured at 1m, at 2.83V in simulated free field conditions as per AES 2-2012 and IEC 60268-5 (Ed.3.1 2007-09). Sensitivity is calculated for 1W/1m conditions as an average SPL within 80Hz-1000Hz frequency band.
4. Specified in accordance with IEC 60268-5 (Ed. 3.1 2007-09). Defines recommended operating frequency band for typical application.
5. X $_{max}$ is defined as $X_{max} = (H_{vc} - H_{gap})/2 + H_{gap}/4$ and based on actual BL linearity data measured for each driver by laser based analyser with 82% BL reduction limit from normalized maximum at voice coil rest position. H $_{vc}$ – voice coil height, H $_{gap}$ – active magnetic gap height.